

AILERONS & COMPONENT PARTS

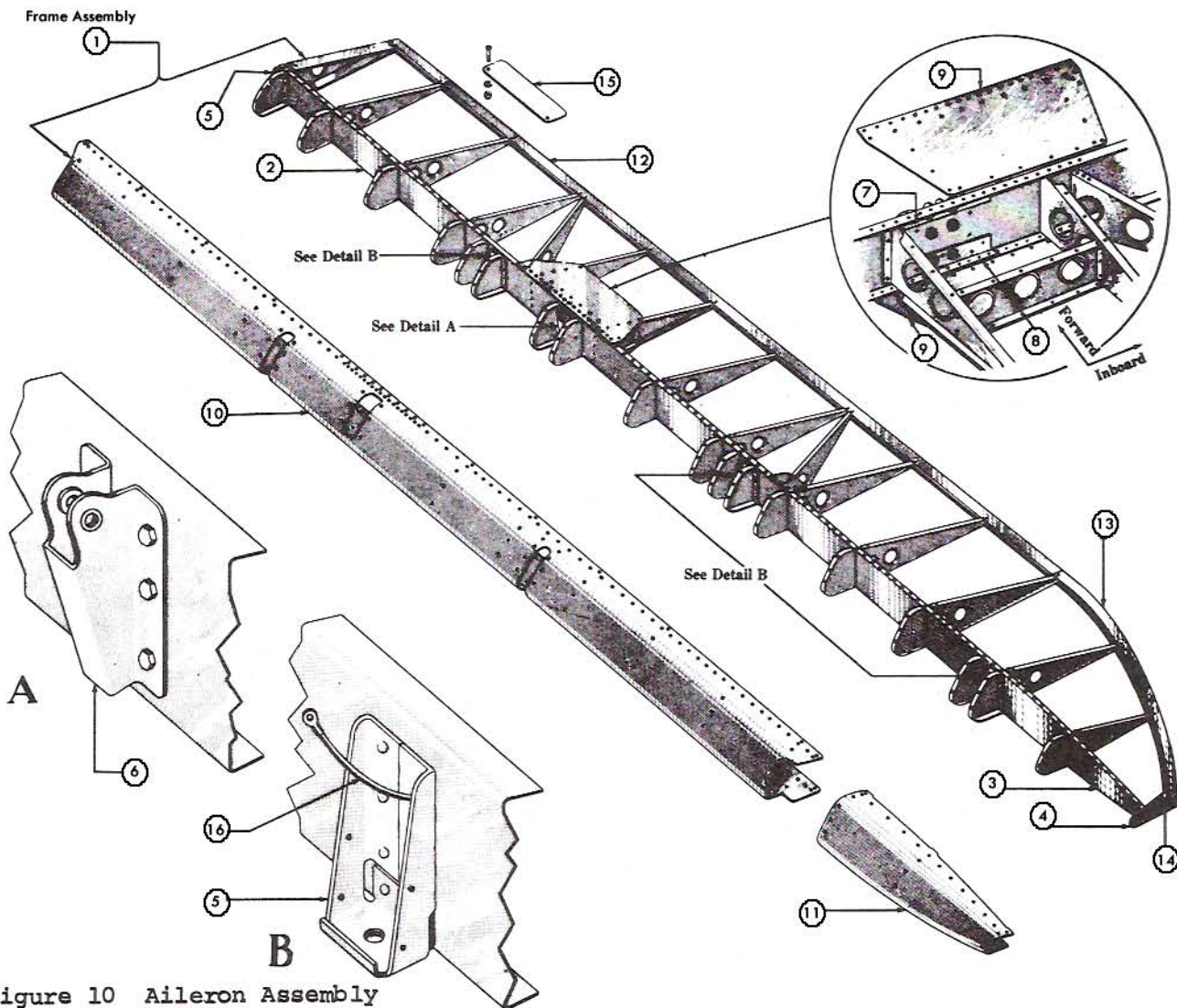

Figure 10 Aileron Assembly

No.	Part No.	Description	Cond.
1	75-1400	Aileron assy, lh covered-grade "A" cotton	
1	75-1400-1	Aileron assy, rh covered-grade "A" cotton	
1	75-1401	Aileron assy-uncovered lh	
1	75-1401-1	Aileron assy-uncovered rh	
2	AG75-1403	Spar-aileron lh	FAA-PMA
2	AG75-1403-1	Spar-aileron rh	FAA-PMA
	75-1423	Rib-aileron root, lh aileron, 1 required	N-P
	75-1423-1	Rib-aileron root, rh aileron, 1 required	N-P
	75-1408	Rib-aileron #4 lh aileron, 9 required	N-P
	75-1408	Rib-aileron #4 rh aileron, 1 required	N-P
	75-1408-1	Rib-aileron #4 lh aileron, 1 required	N-P
	75-1408-1	Rib-aileron #4 rh aileron, 9 required	N-P
	75-1407	Rib-aileron #3 lh aileron, 1 required	N-P
	75-1407-1	Rib-aileron #3 rh aileron, 1 required	N-P
	75-1414	Rib-diagonal lh aileron, 2 required	N-P
	75-1414	Rib-diagonal rh aileron, 2 required	N-P
	75-1420	Gusset-aileron reinforcing, 2 required	N-P
3	75-1404	Spar-aileron tip lh	N-S
3	75-1404-1	Spar-aileron tip rh	N-S

AILERONS & COMPONENT PARTS continued

Figure 10

Index

No.	Part No.	Description	Cond.
	75-1406	Rib-aileron #2, lh aileron, 1 required	N-P
	75-1406-1	Rib-aileron #2, rh aileron, 1 required	N-P
4	75-1405	Rib-aileron #1 lh aileron, 1 required	N-P
4	75-1405-1	Rib-aileron #1 rh aileron, 1 required	N-P
	75-1410	Rib-aileron nose #4 lh, 12 required	N-P
	75-1410	Rib-aileron nose #4 rh, 5 required	N-P
	75-1410-1	Rib-aileron nose #4 lh, 5 required	N-P
	75-1410-1	Rib-aileron nose #4 rh, 12 required	N-P
	75-1411	Rib-aileron nose #2 lh, 1 required	N-P
	75-1411-1	Rib-aileron nose #2 rh, 1 required	N-P
5	75-1419	Support assy-aileron hinge	N-S
	75-1425	Bushing-special flanged, 75-1419 support	N-P
6	AG75-1417	Horn assy-aileron control	FAA-PMA
	AGS-276-6S	Replacement bushing, 75-1417 horn	
	Attach. hdw.	6 ea. AN4DD-5A, 8 ea. AN960D-416, 6 ea. AN365D-428	F/N
7	75-1409-1	Angle-aileron spar reinforcement	N-P
8	75-1409-2	Angle-aileron spar reinforcement	N-P
	75-1422	Bulkhead-aileron	N-P
10	AG75-1413	Cover-aileron leading edge lh	FAA-PMA
10	AG75-1413-1	Cover-aileron leading edge,rh	FAA-PMA
11	AG75-1421	Cover-aileron leading edge tip lh	FAA-PMA
11	AG75-1421	Cover-aileron leading edge tip rh	FAA-PMA
12	75-1415	Trailing edge-aileron, 6061-T6 extrusion	N-P
13	AG75-1416	Trailing edge-aileron tip	FAA-PMA
14	A75N1-1401	Reinforcement-aileron tip rib	N-P
14	A75N1-1401-1	Reinforcement-aileron tip rib	N-P
15	AG75-2007	Tab-rudder trim lh	FAA-PMA
	Attach hdw.	2 ea. AN510-10-14, 4 ea. AN960-10, 2 ea. AN365-1032	
16	3AJ8-8	Jumper-bonding, 3 required	F/N
	E75N1-1401	Fabric slip cover, grade "A", lh or rh	F/N
	AN231-2	Drain grommet, 30 required	F/N
	75-1402-SR	Splice kit-aileron spar	F/N
9	75-1412	Plate-aileron spar reinforcing	N-P