

CARBURETOR AIR HEATER SHROUD & EXHAUST WELL, PT-17, N2S-4

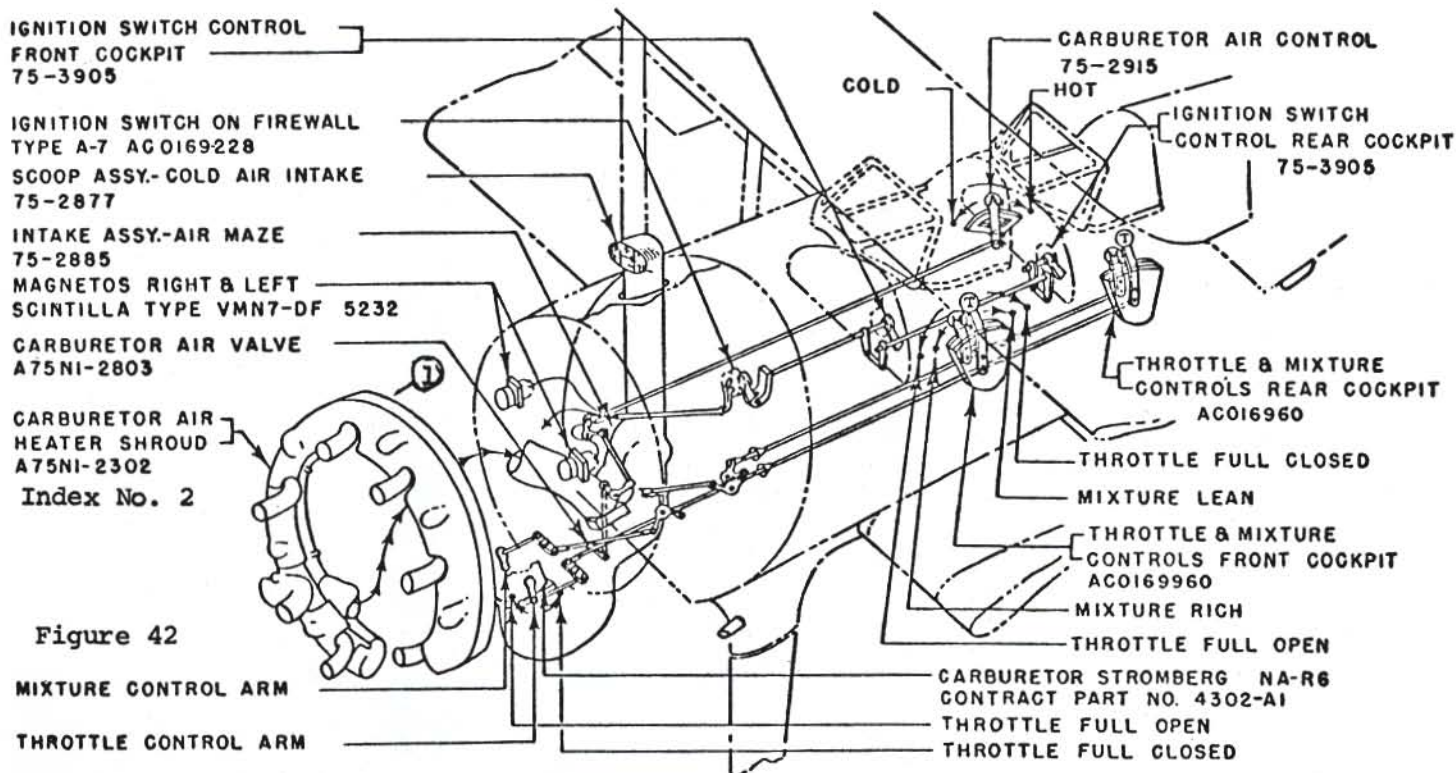

Figure 42

Index

Index No.	Part No.	Description	Cond.
1	A75N1-2302	Well assy-exhaust, 3 pieces to set	N-S
1	A75N1-2302	Well assy-exhaust, 3 pieces to set	Recond.
1	A75N1-2305	Section assy-exhaust well, upper	N-S
1	A75N1-2306	Section assy-exhaust well, left hand	N-S
1	A75N1-2307	Section assy-exhaust well, right hand	N-S
2	AGA75N1-2319C	Exhaust shroud set, 6 pieces, part N-S, part recond.	
2	AGA75N1-2319	Exhaust shroud segment-cylinder #1	FAA-PMA
2	AGA75N1-2320	Exhaust shroud segment, cylinder #7	FAA-PMA
2	AGA75N1-2321	Exhaust shroud segment, cylinder #2	FAA-PMA
2	AGA75N1-2322	Exhaust shroud segment, cylinder #6	FAA-PMA
2	AGA75N1-2325	Exhaust shroud segment, cylinder #3	FAA-PMA
2	AGA75N1-2326	Exhaust shroud segment, cylinder #5	FAA-PMA